

## PRODUCT DATA

# CORRATOR PROBE 6112

### Product Uses

The 6112 Corrator Probe is ideal for laboratory testing or light duty plant operations in a bypass rack where removal under system pressure is not required. This probe uses two replaceable electrodes, which are mounted at the end of the probe by threaded insulated studs, suitable for the majority of problems where LPR techniques are applicable. A wide range of electrode materials are available.

Used by major company's worldwide to measure corrosion in waterfloods, cooling water loops and other aqueous systems and to provide control inhibitor addition for optimum economy and corrosion protection.

### Product Application and Uses

Use with the AquaMate.

The probe may not be removed under pressure.

### General Specification

Mounting – optional adjustable nylon swage fitting.

Temperature Rating – 150<sup>0</sup>C max.

Pressure Rating – 100 PSI/690 kPa.

Electrode Seal Material – Epoxy.

Fill Material – Epoxy.

Body Material – Glass Steel.

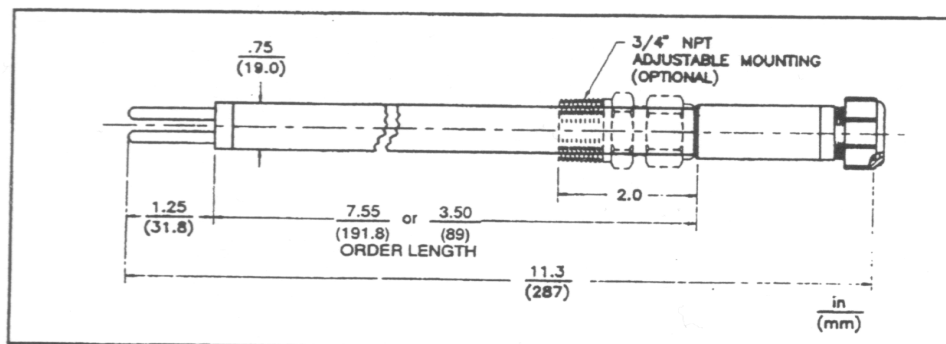

Corrator Probe6112/pdi/18/02/15